

Products made of PTFE-M

Column internals

Support grids
Spraying Distributors
Demisters

Fittings

Butterfly shut-off Valves
Butterfly Throttle Valves
Inspection glasses
Dirt traps

Non serial constructions on demand

Furthermore we manufacture:
Fluoroplastics: PTFE pure white
Weldable plastics: PTFE-M, ECTFE, PFA
Special materials: PVC-C, PVDF, PP-el

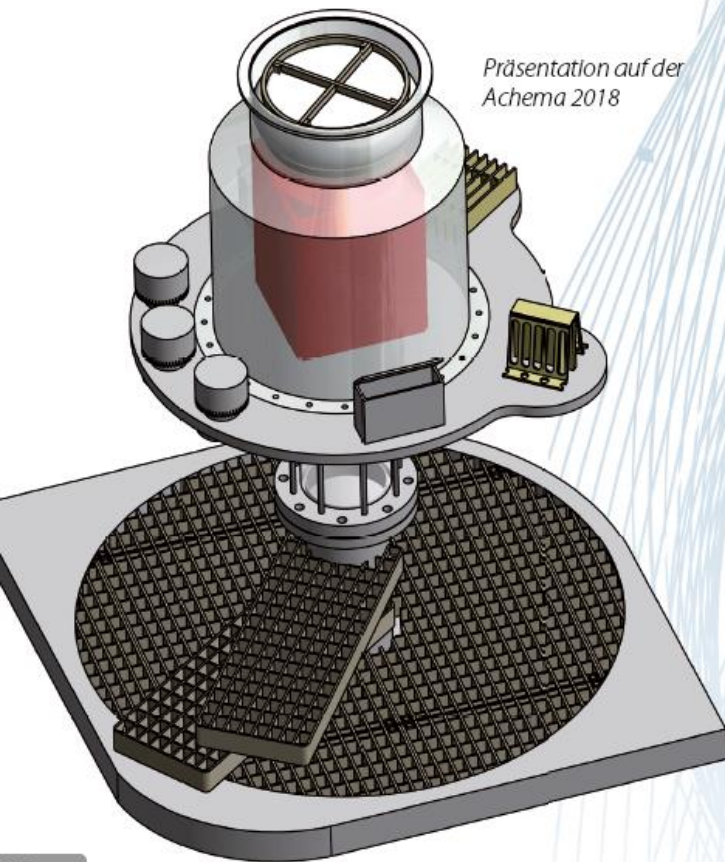

Präsentation auf der
Achema 2018



You find the overall product range in the different dimensions and materials in our catalogues.

Order your copy via telephone, fax or e-mail.



SCHRUPP GMBH

Hauptstraße 33
D-56472 Nisterberg
www.sktschrupp.de
Tel. +49 (0)2661 98 23 6-0
FAX +49 (0)2661 98 23 6-36
E-Mail: info@sktschrupp.de



SCHRUPP GMBH

PTFE-M

Welding constructions

PTFE Compounds

By the addition of filler (further processing to PTFE-based compounds), the PTFE-M features get optimized. Especially the production of customer-specific compounds makes flexible and individual solutions possible.

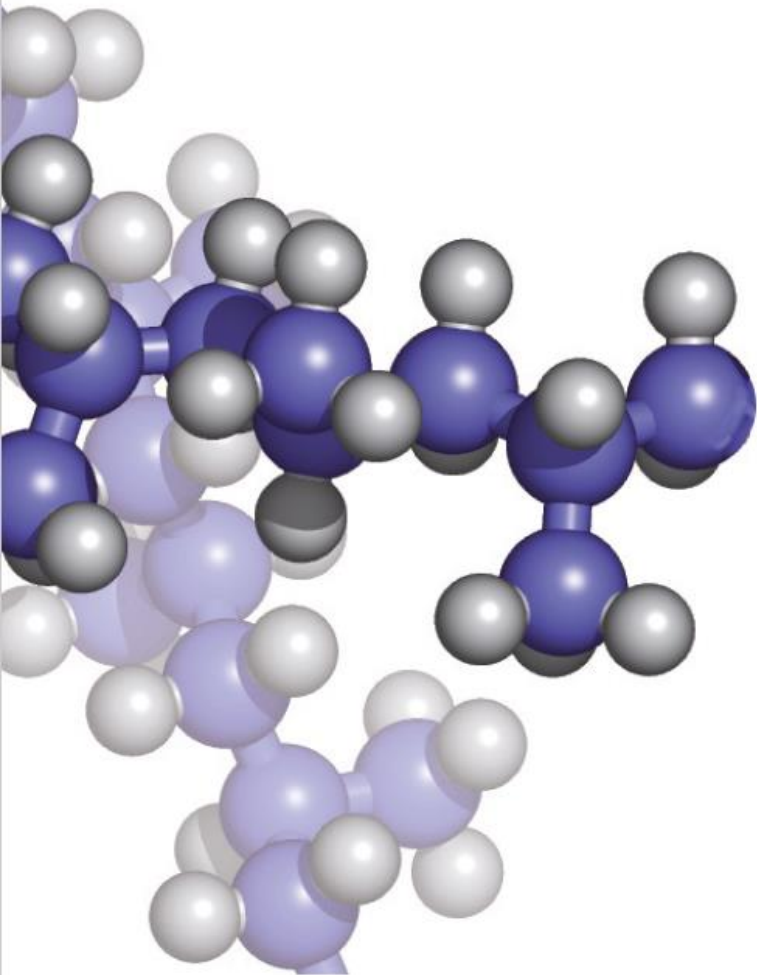

Chemical resistance

PTFE-M has nearly universal chemical resistance by the strength of the carbon-fluorine bond and of the fact that the carbon chains are shielded completely by an arrangement of fluorine atoms. Aggressive substances, for example hydrochloric acid, hydrofluoric acid, concentrated sulphuric acid or fuming nitric acid, acid chlorides, hot sodium hydroxide solutions and chlorine gas, hydrazine or nitrogen oxide have no influence on PTFE-M. Moreover, alcohols, ester, ketones or hydrocarbons have no impact on PTFE-M as well.

It is unnecessary to create a separated chemical resistance list for PTFE-M.

NEW! Weldability of PTFE-M

The reduced molecular weight of PTFE-M makes this material weldable. Therefore, particular requirements are necessary. For example, the use of specific clamping devices and on the market available extruders, which are especially produced for PTFE-M, are crucial. Taking account of the current safety regulations, we produce the SKT products, which you are familiar with, in PTFE-M now. Specifically for the processing of fluorine plastics, we have an established production line.



Mass transfer tray with welded rib design for stabilization.
(Plate thickness: 30 mm)